



ICC Evaluation Service, Inc.
www.icc-es.org

Business/Regional Office ■ 5360 Workman Mill Road, Whittier, California 90601 ■ (562) 699-0543
Regional Office ■ 900 Montclair Road, Suite A, Birmingham, Alabama 35213 ■ (205) 599-9800
Regional Office ■ 4051 West Flossmoor Road, Country Club Hills, Illinois 60478 ■ (708) 799-2305

Legacy report on the BOCA® National Building Code/1999 and the 1998 International One- and Two-Family Dwelling Code®

DIVISION: 06—WOOD AND PLASTICS
Section: 06090—Wood and Plastic Fastenings

REPORT HOLDER:

GORDON MACHINERY & SUPPLY CO., LLC
27544 GROESBECK HIGHWAY
ROSEVILLE, MICHIGAN 48066
gordmac@aol.com

EVALUATION SUBJECT:

GORDON FA-14X, FA-22X, FA-14, FA-19, AND FA-22
FOUNDATION ANCHORS, GORDON 'J' AND 'JD'
SERIES JOIST HANGERS AND GORDON T-BRACE

EVALUATION SCOPE

Compliance with the following codes:

BOCA® National Building Code/1999

- Section 106.4 Alternative materials and equipment
Section 2305.7 Wind bracing
Section 2305.17 Foundation anchorage
Section 2312.2 Vertical load capacity

1998 International One- and Two-Family Dwelling Code®

- Section 108.1 Alternative materials, methods and equipment
Section 301.2 Climatic and Geographic Design Criteria

DESCRIPTION

■ Gordon Foundation Anchors

Gordon Foundation Anchors are used to anchor nominal 2-by-4-, 2-by-6-, and 2-by-8-inch (51x102, 51x152 and 51x203 mm) wood sill plates to cast-in-place concrete and grouted unit masonry foundations. The FA-19 model is used with a double sill plate. The anchors are installed with one end embedded in cast-in-place concrete or a grouted unit masonry foundation and the other end extending above the top of the foundation. Gordon Foundation Anchors are manufactured from 0.0478-inch-thick (1.21 mm) hot-dipped galvanized steel which conforms to ASTM A653/653M with a minimum yield strength of 41 ksi (317 MPa) and minimum ultimate strength of 55 ksi (426 MPa). The exposed end is fabricated with a slit down the middle, lengthwise to create two "legs." Each "leg" is wrapped around one side of the wood sill plate and fastened to the plate with a minimum of two 4d sinker nails per leg. See Figure 1 of this report for installation details.

The foundation anchors shall be installed in accordance with the limitations set forth in this report. Intermediate spacing of anchors, configuration, dimensions, and allowable design loads

of the Foundation Anchors are shown in Figure 1, Table 1 and Table 2 of this report.

Installation: The use of Gordon Machinery Foundation Anchors as an alternative to 1/2-inch-diameter (12.7 mm) anchor bolt foundation anchorage requirements prescribed by the code is subject to the following installation requirements:

- Cast-in-place concrete foundations shall have a minimum f'c at 28 days of 3 000 lbf/in² (20 700 kPa);
Wood sill plates shall have a minimum size of 2-by-4-inch (51x102 mm) and a maximum size of 2-by-8-inch (51x203 mm) with a minimum specific gravity equivalent to 0.55 for Southern Yellow Pine (SYP);
A minimum of two anchors per sill plate is required, with the maximum spacing of intermediate anchors not to exceed the dimensions stated in Table 2 of this report;
One anchor is to be located within 12 inches (305 mm) of each end of each sill plate;
Each anchor shall be fastened to the sill plate with a minimum of two 4d sinker nails per each leg of the anchor (4 total per anchor) - one in the top and one in the side of the sill plate at each leg;
The allowable design loads for the anchors shall not exceed the values stated in Table 1 of this report;
The minimum embedment depth of the anchor into the foundation shall be 6 1/4 inches (159 mm).

■ Gordon 'J' and 'JD' Series Joist Hangers

Gordon 'J' and 'JD' Series Joist Hangers are U-shaped metal fasteners that are available in several lengths as indicated in Figure 2 and Table 3 of this report. The hangers are used for the attachment of wood joists to wood headers, beams, or girders. The 'J' Series Joist Hangers provide support for single wood joists. The 'JD' Series Joist Hangers are used for double joists.

The hangers are manufactured from hot-dipped galvanized steel which conforms to ASTM A653/653M with a minimum yield strength of 41 ksi (317 MPa) and minimum ultimate strength of 55 ksi (426 MPa). The 'J' series fastener is stamped from 18 gauge galvanized steel and the 'JD' series fastener is stamped from 16 gauge galvanized steel. See Table 3 of this report for hanger dimensions. Allowable design loads for the joist hangers are given in Table 4 of this report.

■ Gordon T-Brace

Gordon T-Brace is intended for use as wind bracing in wood frame construction. The T-Brace shall be installed at an angle of 45° (0.78 rad) at the corner of walls which have a maximum

ICC-ES legacy reports are not to be construed as representing aesthetics or any other attributes not specifically addressed, nor are they to be construed as an endorsement of the subject of the report or a recommendation for its use. There is no warranty by ICC Evaluation Service, Inc., express or implied, as to any finding or other matter in this report, or as to any product covered by the report.

stud spacing of 16 inches (406 mm) on center and a maximum height of 8 feet (2438 mm). A $\frac{1}{2}$ -inch-deep (12.7 mm) saw kerf is cut in each stud along the line where the brace intersects the stud. The stem of the T-Brace is then inserted into the saw kerf at each stud. The brace is attached to the top and bottom plates with two 12d nails and at each stud with three 12d nails. The design lateral load on the Gordon T-Brace shall not exceed 370 lbf (168 kg).

The Gordon T-Brace is a 20 gauge galvanized steel strip, cold formed to a 'T' configuration as shown in Figure 3 of this report. The stem of the 'T' is $\frac{1}{2}$ -inch (12.7 mm) and the width is $1\frac{7}{8}$ -inch (48 mm). The T-Brace is manufactured from hot-dipped galvanized steel sheets which conform to ASTM A653/653M with a minimum yield strength of 41 ksi (317 MPa) and minimum ultimate strength of 55 ksi (426 MPA).

CONDITIONS OF USE

This report is limited to the applications and products as stated herein. The ICC-ES Subcommittee on National Codes intends that the report be used by the code official to determine that the report subject complies with the code requirements specifically addressed, provided that this product is installed in accordance with the following conditions:

- Gordon Machinery Foundation Anchors, 'J' and 'JD' Series Joist Hangers and T-Brace shall be installed in accordance with this report and the manufacturer's published installation instructions.
- All framing members and mechanical connections shall be designed in accordance with the design specifications referenced in the applicable code. Design of the framing members is outside the scope of this report.
- Load capacities for the foundation anchors indicated in Table 1 of this report are limited to No. 2 Southern Yellow Pine (specific gravity = 0.55) installed in dry conditions of use. Dry conditions of use are those environmental conditions at which the moisture content is less than 16 percent.
- Gordon 'J' and 'JD' Series Joist Hangers shall be limited to use in supporting floor joists and other horizontal framing members which are not subject to wind uplift or torsional moment.
- The allowable loads of the Gordon 'J' and 'JD' Series Joist Hangers shall not exceed those set forth in Table 4 of this report. The vertical loads are valid for downward loads only.
- The use of Gordon T-Brace as wind bracing in wood frame construction shall be limited to the installation stated in this report.
- When using ACQ pressure treated wood, fasteners shall be hot-dipped galvanized or stainless steel.

ITEMS REQUIRING VERIFICATION

The following items are related to the installation of the report subject, but are not within the scope of this evaluation. However, these items are related to the determination of code compliance:

- Construction documents and details utilizing the allowable design values in this report to verify compliance with this report.

INFORMATION SUBMITTED

- Progressive Engineering, Inc., Test Report No. 95-1284, dated September 15, 1995, containing concrete foundation anchor tests of Gordon FA-14 Foundation Anchors.
- Structural calculations, dated September 20, 1995 determining the load-carrying capacity of FA-14 anchors with $\frac{1}{2}$ -inch-diameter (12.7 mm) anchor bolts in concrete foundation walls.
- National Testing and Research Laboratory, Inc., Test Series 88759-1 thru 7, dated November 17 and 18, 1988, containing vertical load testing of the 'J' and 'JD' joist hangers in accordance with ASTM D1761.

- Shepard Engineering, Inc., Structural Calculations, Joist Hanger Capacities, Job No. 89-1094-A, dated September 26, 1994.
- Pittsburgh Testing Laboratory, Lab No. 787119 and 792633, dated June 27, 1978 and December 13, 1978, respectively, containing racking tests on wall panels with T-Brace in accordance with ASTM E72.
- Progressive Engineering, Inc., Test Report No. 2003-234, dated February 4, 2003, containing concrete foundation anchor tests of Gordon FA-19 Foundation Anchors with double sill plates to determine the average ultimate design loads.

APPLICATION FOR PERMIT

To aid in the determination of compliance with this report, the following represents the minimum level of information to accompany the application for permit:

- The language "See ICC-ES Legacy Report No. 22-04" or a copy of this report.
- The manufacturer shall provide the user of this report with complete instructions for the installation requirements for the products described in this report.
- Design calculations and details for specific applications shall be furnished to the code official verifying compliance with this report and the applicable codes. The individual preparing such documents shall possess the necessary credentials regarding competency and qualifications as required by the applicable code and the professional registration laws of the state where the construction is undertaken. Where applicable, Tables 1, 2, 3, and 4 of this report are intended to serve as alternatives to the design calculations for the items covered in the tables. Construction documents including, at a minimum, the following:
 - **Foundation Anchors:**
 - Name and model of Gordon Machinery anchors to be used;
 - Design loads for the structure and the maximum design load resisted at the connector;
 - The maximum permitted spacing of anchors;
 - Foundation wall details, including type of foundation, sill plate and size and minimum embedment of anchors;
 - The lumber grade, species and specific gravity of the wood sill plate;
 - Nailing schedule of anchor to sill plate.
 - **'J' and 'JD' Series Joist Hangers and T-Brace:**
 - Maximum design loads anticipated at the hanger or brace, based on Chapter 16 of the BOCA[®] *National Building Code/1999* or Chapter 3 of the 1998 *International One- and Two-Family Dwelling Code*[®];
 - A fastener schedule which specifies the type, quantity, and location of the fasteners that secure the brace or joist hanger to the supporting structure;
 - Identification of the species or specific gravity of the wood members to which the brace or joist hangers are secured;
 - Details of installation of the 'J' and 'JD' Series Joist Hangers and T-Brace in accordance with this report.

PRODUCT IDENTIFICATION

Gordon Machinery and Supply Co., Inc. Foundation Anchors, 'J' and 'JD' Series Joist Hangers, and T-Brace manufactured in accordance with this report shall be marked with the identifying language

- "See ICC-ES Legacy Report No. 22-04."

TABLE 1—FOUNDATION ANCHOR DIMENSIONS AND ALLOWABLE DESIGN LOADS¹

ANCHOR CLIP	ANCHOR DIMENSIONS (in.)				DIRECTION OF LOAD ¹ (lbf)		
	A	B	C	D	Perpendicular	Parallel	Vertical
FA-14X	14 ³ / ₄	6 ⁷ / ₈	1 ¹ / ₄	5 ⁵ / ₈	538	560	452
FA-22X	22 ³ / ₄	6 ⁷ / ₈	1 ¹ / ₄	5 ⁵ / ₈	538	560	452
FA-14	13 ¹ / ₄	6 ⁷ / ₈	1 ¹ / ₄	5 ⁵ / ₈	538	560	452
FA-22	21 ¹ / ₄	6 ⁷ / ₈	1 ¹ / ₄	5 ⁵ / ₈	538	560	452
FA-19	17 ¹ / ₂	10 ⁷ / ₈	1 ¹ / ₄	5 ⁵ / ₈	580	408	440

For SI: 1 in. = 25.4 mm, 1 lbf = 4.4 N.

¹Load duration adjustments shall not be applied to the design loads indicated.

FA-14X, AND FA-22X FOUNDATION ANCHOR

FA-14, AND FA-22 FOUNDATION ANCHOR

FA-19 FOUNDATION ANCHOR

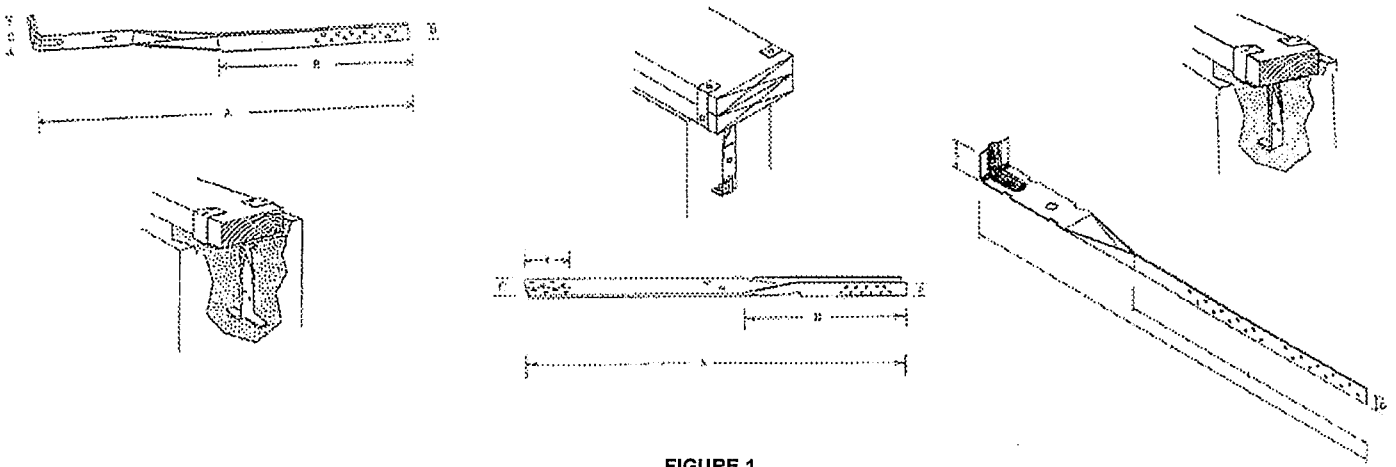

FIGURE 1

TABLE 2—INTERMEDIATE SPACING OF FOUNDATION ANCHOR^{1,2}

TYPE OF WOOD FRAME STRUCTURE	MAXIMUM INTERMEDIATE SPACING					
	FA-14X	FA-22X	FA-14	FA-22	FA-19	1/2 in. Anchor Bolts
1 & 2 Story Buildings which are: •• Detached 1 & 2 Family Dwellings in seismic area having a peak velocity acceleration (A _v) ≤ 0.15; or •• All others in a seismic area having a peak velocity acceleration (A _v) > 0.05	3'-8"	3'-8"	3'-8"	3'-8"	2'-4"	6'-0"
Buildings over 2 stories which are: •• Detached 1 & 2 Family Dwellings in seismic area having a peak velocity acceleration (A _v) ≤ 0.15; or •• All others in a seismic area having a peak velocity acceleration (A _v) > 0.05	2'-5"	2'-5"	2'-5"	2'-5"	1'-6"	4'-0"
All other buildings	4'-10"	4'-10"	4'-10"	4'-10"	3'-1"	8'-0"

For SI: 1 in. = 25.4 mm, 1 ft = 304.8 mm.

¹As required by Section 2305.17 of the BOCA® National Building Code/1999 or Section 403.1.4 of the 1998 International One- and Two-Family Dwelling Code®.

²Anchors spacing is based on the requirements stated in of this report.

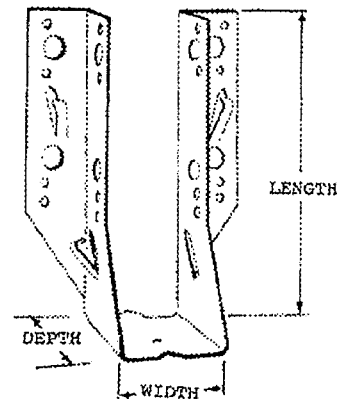

FIGURE 2—GORDON 'J' and 'JD' JOIST HANGER

TABLE 3—GORDON 'J' AND 'JD' SERIES JOIST HANGER

HANGER DIMENSIONS (in.)							
Designation	J-100	J-200	J-300	J-400	JD-200	JD-300	JD-400
Length	3 1/4	5	7	8 1/2	5 1/4	7 1/8	8 1/2
Width	1 9/16	1 9/16	1 9/16	1 9/16	3 1/16	3 1/16	3 1/16
Depth	2	2	2	2	2 3/4	2 3/4	2 3/4

For SI: 1 in. = 25.4 mm.

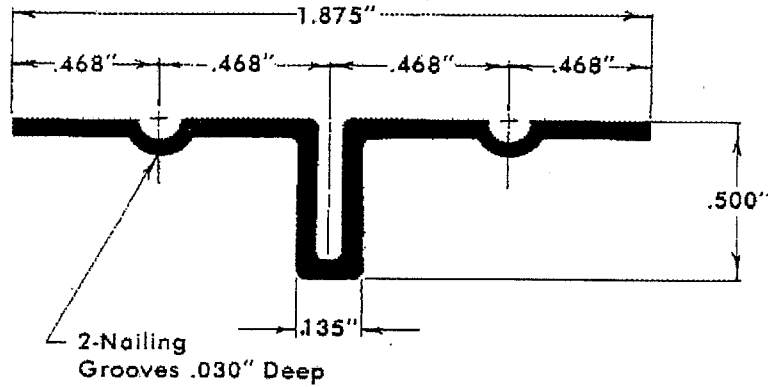

FIGURE 3—GORDON T-BRACE

TABLE 4—ALLOWABLE VERTICAL DESIGN LOADS FOR GORDON JOIST HANGER¹ (LBF)

WOOD SPECIES /SPECIFIC GRAVITY	HANGER DESIGNATION / (Nail qty - ea) NAIL SIZE ^{2,3}						
	J-100 (4) 10d	J-200 (6) 10d	J-300 (10) 10d	J-400 (12) 10d	JD-200 (8) 16d	JD-300 (12) 16d	JD-400 (14) 16d
Red Oak 0.67	568	852	1420	1704	1370	2040	2380
Mixed Maple Southern Pine 0.55	484	726	1210	1452	1160	1740	2030
Douglas Fir-Larch 0.50	448	672	1120	1344	1072	1608	1876
Douglas Fir (S) Hem-Fir (N) 0.46	420	630	1050	1260	1000	1500	1750
Hem-Fir 0.63	392	588	980	1176	944	1416	1652
Spruce-Pine-Fir 0.42	384	576	960	1152	928	1392	1624
Redwood (open grain) 0.37	344	516	860	1032	832	1248	1456
Eastern Softwoods Spruce-Pine-Fir (S) Western Cedars Western Woods 0.36	340	510	850	1020	816	1224	1428
Northern Species 0.35	328	492	820	984	792	1188	1386

For SI: 1 lbf = 4.4 N.

¹These values are for loads of normal duration. Adjustments for loads of shorter or longer duration shall be in accordance with the American Forest Products Association's *National Design Specification (AFPA NDS-97)*,

²These values are based on the allowable common wire nail design values for single shear in accordance with AFPA NDS-97.

³Required number of nails securing the joist hanger to the supporting wood member.